

CARACTERÍSTICAS / FEATURES

Material hormigón Petra1
Acabado decapado e hidrofugado
Dimensiones l. 80, a. 60, h. 82 cm
Color ver carta de colores
Fijación simplemente apoyado o mediante resina epoxy
Peso 310 Kg
Palet 120 x 80 x 100cm
Peso palet 340 Kg

Material precast concrete preta 1
Finish scaled and waterproofed
Dimensions l. 80, w. 60, h. 82 cm
Colour see colour catalogue
Fixing resting on the ground or anchored with epoxy resin
Weight 310 Kg
Pallet 120 x 80 x 100cm
Weight pallet 340 Kg

diseñador / design: Roger Albero

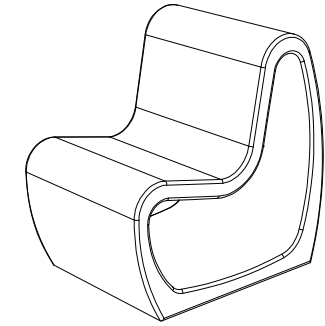

GEOMETRIA / GEOMETRY

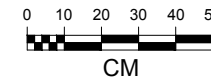
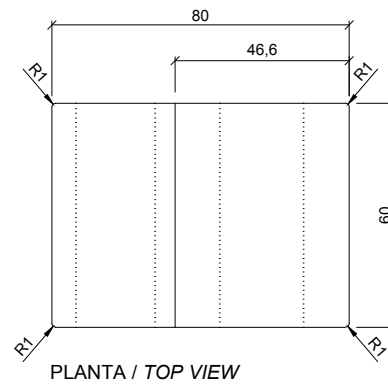
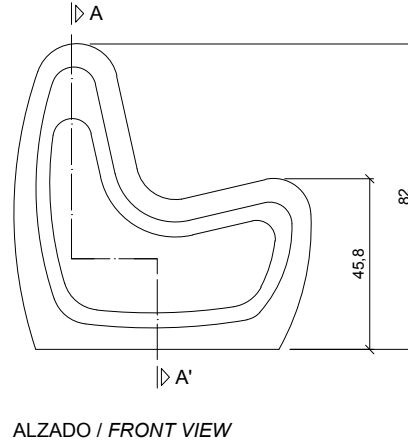
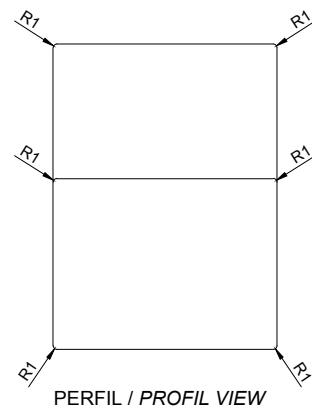

MANIPULACIÓN E INSTALACIÓN / HANDLING AND INSTALLATION

1 verter resina epoxy / pour resin epoxy

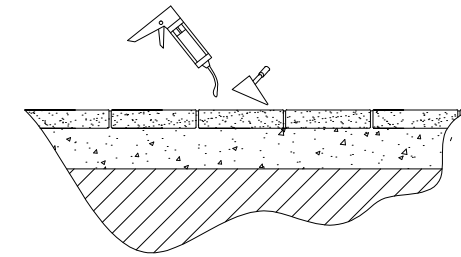

2 elevar mediante eslingas para instalar / lift with slings for install

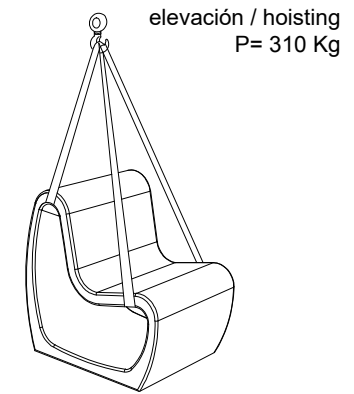

ESPECIFICACIONES / SPECIFICATIONS

