

CARACTERÍSTICAS / FEATURES

Material hormigón Petra1
Acabado decapado e hidrofugado
Dimensiones l. 160, a. 160, h. 8 cm
Color ver carta de colores
Fijación simplemente apoyado
Peso / Capacidad 374 Kg
Palet 160 x 80 x 80 cm [3u]
Peso bruto 1140 Kg

Material precast concrete Petra1
Finish scaled & waterproofed
Dimensions l. 160, w. 160, h. 8 cm
Colour see colour catalogue
Fixing resting on the ground
Weight / Capacity 374 Kg
Package 160 x 80 x 80 cm [3u]
Weight package 1140 Kg

diseñador / design: Ernest Perera

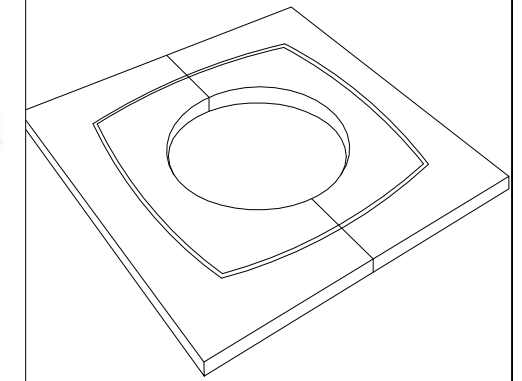

GEOMETRIA / GEOMETRY

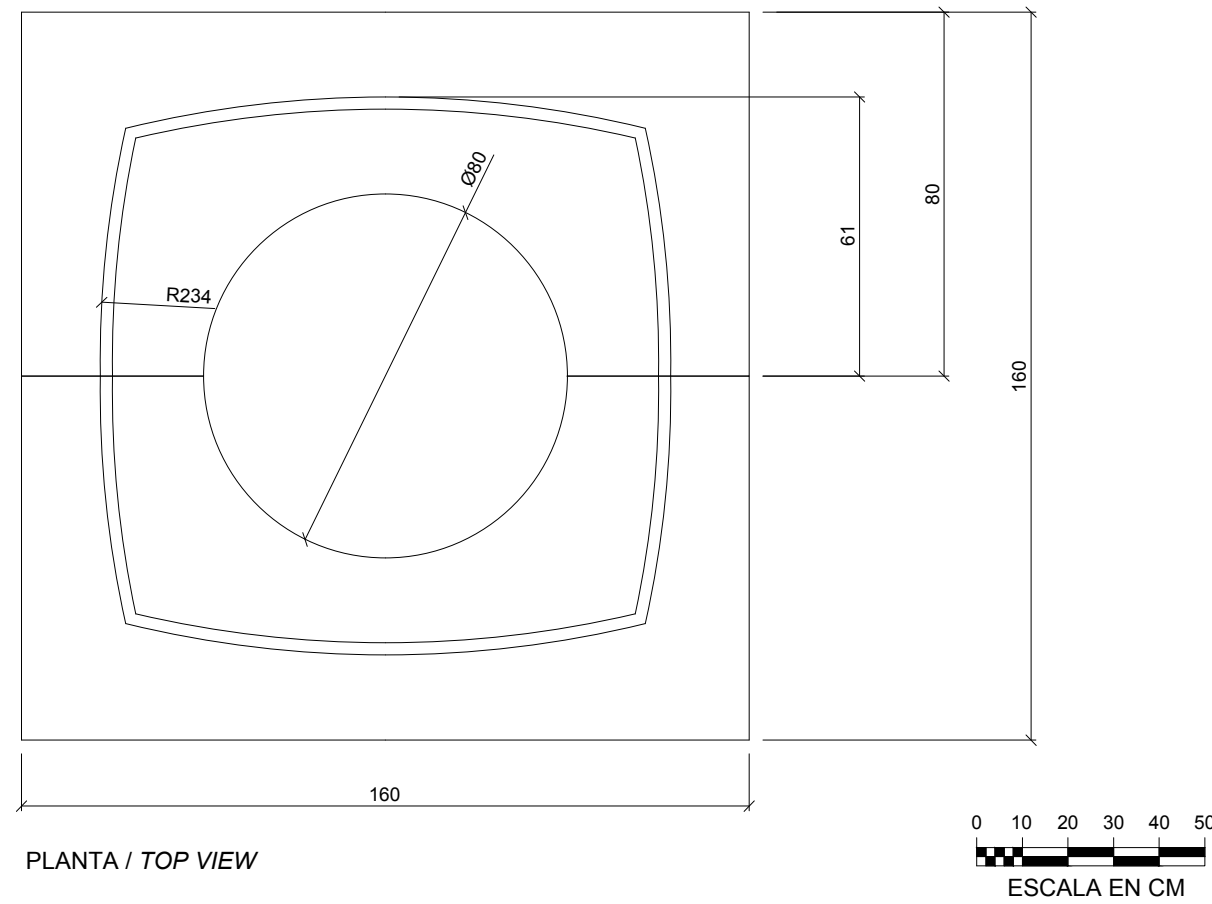

MANIPULACIÓN E INSTALACIÓN / HANDLING AND INSTALLATION

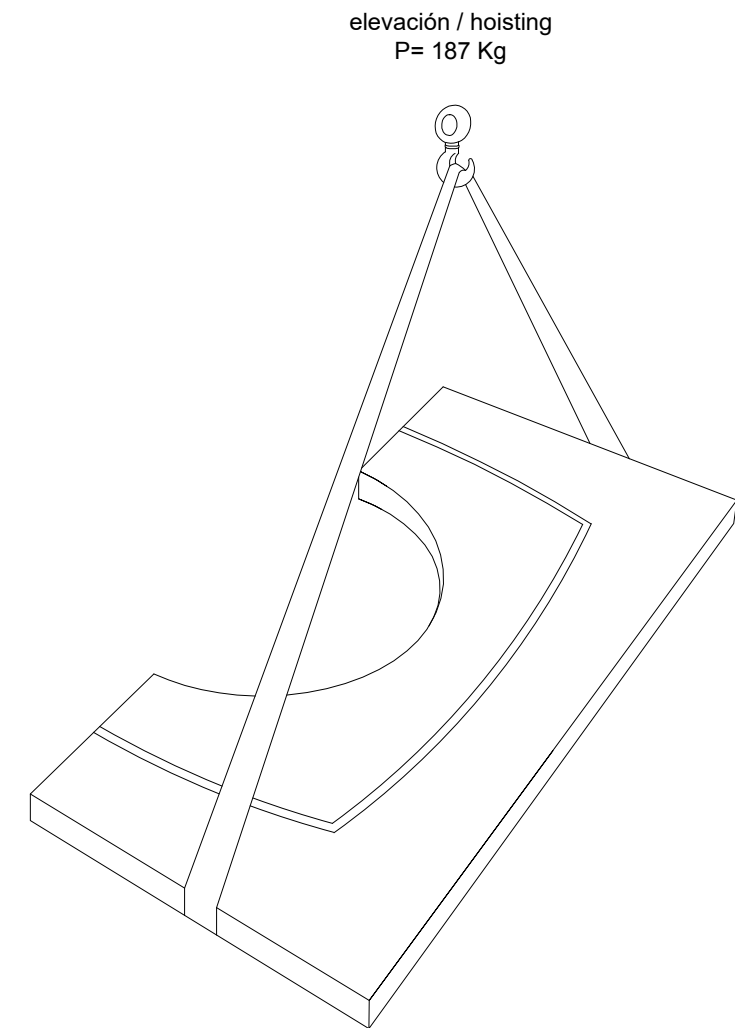

ESPECIFICACIONES / SPECIFICATIONS

