

CARACTERISTICAS / FEATURES

Material hormigón Petra 1
Acabado decapado e hidrofugado
Dimensiones l. 104, a. 50, h. 84 cm
Color ver carta de colores
Fijación simplemente apoyado o mediante resina epoxi
Peso 340 kg
Palet 120 x 100 x 100h cm (2 unidades)
Peso palet 700 kg

Material precast concrete Petra 1
Finish scaled and waterproofed
Dimensions l.104, w.50, h. 84 cm
Colour see colour catalogue
Fixing resting on the ground or with epoxy resin
Weight 340 kg
Pallet 120 x 100 x 100h cm (2 units)
Weight pallet 700 kg

diseñador / design: *Hesús Alfaro, Ana Hurtado*

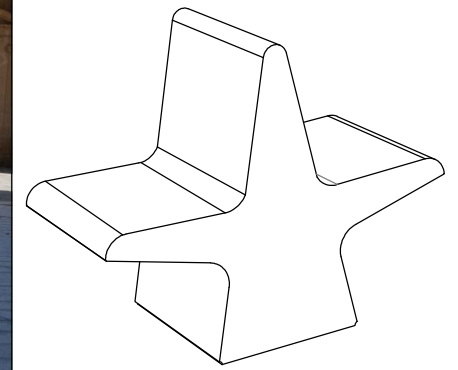

LUCE

GEOMETRIA / GEOMETRY

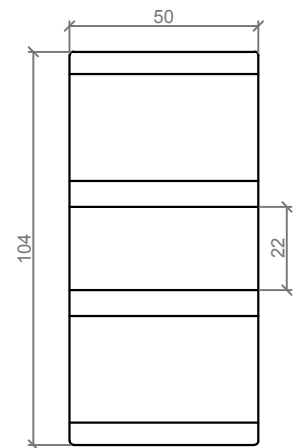

PLANTA / TOP VIEW

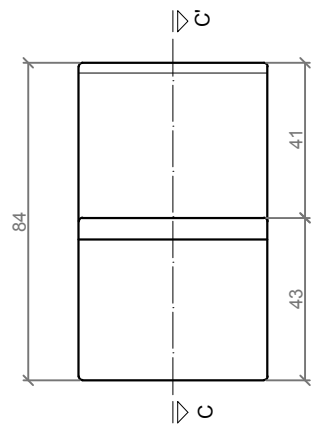

ALZADO / FRONT SIDE

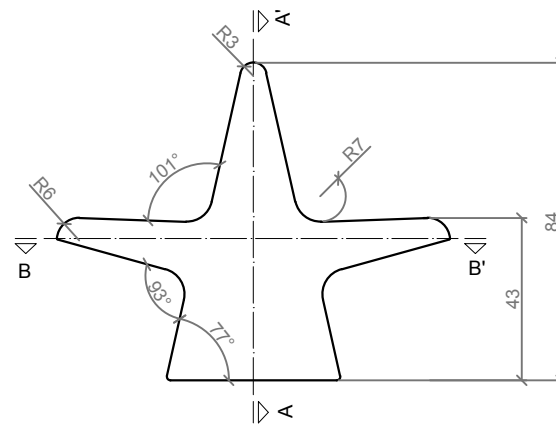

PERFIL / PROFILE

ESCALA / SCALE : 1/ 20

MANIPULACION E INSTALACION / HANDLING AND INSTALLATION

1 Elevar mediante eslingas de poliéster / Lift by polyester slings

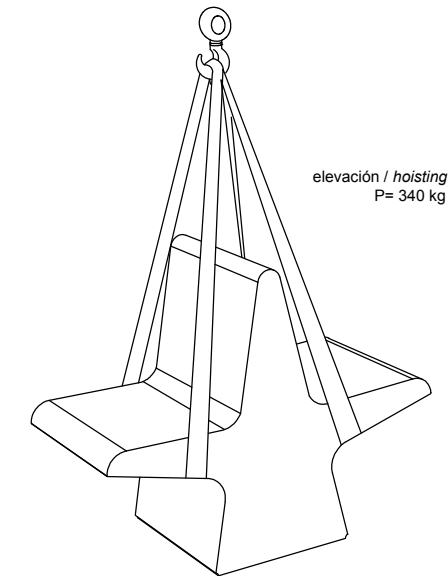

elevación / hoisting
P= 340 kg

2 Verter resina epoxi en el pavimento e instalar el banco / Pour epoxy resin on the pavement and install the bench

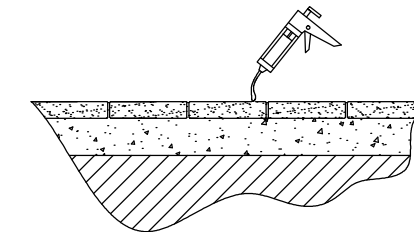

ESPECIFICACIONES / SPECIFICATIONS

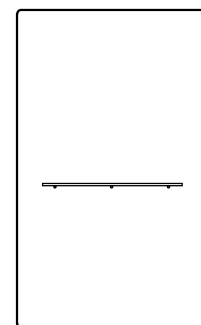

SECCION / SECTION: A-A'

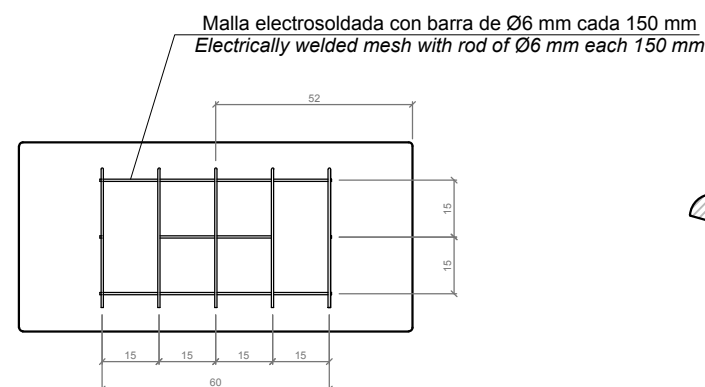

SECCION / SECTION: B-B'

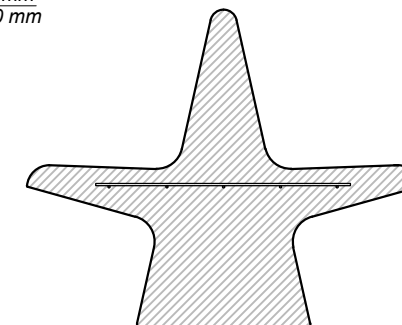

SECCION / SECTION: C-C'

ESCALA / SCALE : 1/ 20